

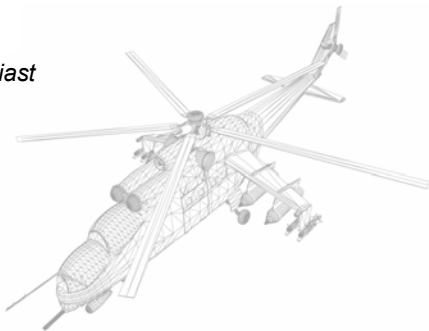

**medusa
research** Inc.

Engineered Products for the RC Enthusiast

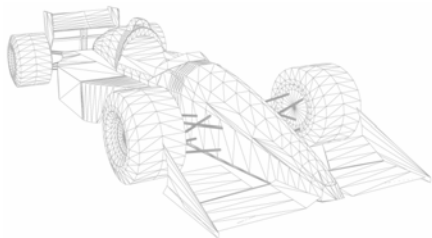

Potencia HIGH VOLTAGE BEC

Operation Manual

Models: MR-BEC-45035-x
MR-BEC-35020-x
MR-BEC-35015-x

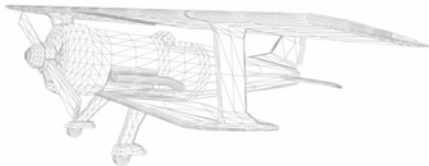

www.MedusaProducts.com

OVERVIEW

Medusa Research's line of switching Battery Eliminator Circuits (BECs) are designed to eliminate many of the common problems with flight pack batteries and the "linear regulator" BEC circuits used in many ESCs.

Our 5 volt and 6 volt models for receivers and servos,

are designed to replace your flight pack or ESC's BEC. Most linear regulator BEC circuits are not able to power servos that demand high currents or work in models that use a high voltage main battery. In these situations, standard linear regulators waste significant amounts of power or worse, they overheat and fail. Flight packs suffer problems as well. They add weight to the model and are a nuisance to charge and maintain. A *Potencia* BEC takes care of these problems so you can spend less time futzing, and more time flying!

Our 9* volt model is exclusively for powering 9 volt accessories such as mini cameras off the main battery. This model frees you from needing to waste your money on alkaline batteries, or maintain rechargeable batteries. Just plug in the main battery, your accessories are powered and your ready to fly!



1.5 Amp BEC MR-BEC-35015-X

- **1.5 Amps continuous** output over the entire input voltage range
- **2.0 Amps peak**
- **Runs 3 standard servos**
- **5V to 35V** input voltage range
- Use **6 to 25 NiMH/NiCd** cell or **2 to 8 lithium** cell battery packs.
- Available in **5 or 6 volt** outputs

2 Amp BEC MR-BEC-35020-X

- **2.0 Amps continuous** output over the entire input voltage range (1.7A for 9V model, see *Specifications*)
- **2.4 Amps peak**
- **Runs 4 standard servos**
- **5V to 35V** input voltage range
- Use **6 to 25 NiMH/NiCd** cell or **2 to 8 lithium** cell battery packs.
- Available in **5, 6 and 9* volt** outputs

3.5 Amp BEC MR-BEC-45035-X

- **3.5 Amps continuous** output over the entire input voltage range
- **4.0 Amps peak**
- **Runs 8 standard servos**
- **8V to 45V** input voltage range
- Use **10 to 33 NiMH/NiCd** cell or **3 to 10 lithium** cell battery packs.
- Available in **5V/6V user switchable voltage** output.

*Our 9 volt model is designed to power 9 volt accessories only. It **CANNOT** be used to power a receiver and servos

INSTALLATION	1
Input Connection.....	1
Locating the <i>Potencia</i> BEC in your model.....	2
Connecting the BEC output to a receiver or accessory.....	2
BEC models with an ESC Pass-Thru Connector.....	2
BEC models without an ESC Pass-Thru Connector.....	3
Connecting a 9V BEC model.....	3
Voltage Selection.....	4
LED Power Indicator.....	5
Connecting BEC's in Parallel.....	5
Operating the BEC in your model.....	5
 TROUBLESHOOTING	 6
 SPECIFICATIONS	 7
<i>Potencia</i> 3.5 Amp BEC.....	7
<i>Potencia</i> 2.0 Amp BEC.....	8
<i>Potencia</i> 1.5 Amp BEC.....	9

APPENDIX	10
About servo ratings.....	10
About voltage ripple.....	10
SUPPORT	11
RETURNS AND RETURN AUTHORIZATION	12
WARRANTY	13

INPUT CONNECTION (ALL MODELS)

Connecting the *Potencia* BEC will require some minor modification to the model's wiring. The input cable has a **red positive** wire and a **brown negative** wire. Polarity on the INPUT connector is vitally important, powering up the BEC with the wrong polarity will damage the BEC. First, attach the ESC battery wires and BEC battery wires together as shown below, then connect the wires onto the terminals of your connector.

As shown in the diagram below, keep the main battery wires short to improve the BEC performance, this is especially important with high current motors. Large current draws on the battery can produce ripples in the voltage across long wires. This ripple is most pronounced further away from the battery, and can be aggravated by poor soldering and poor connections. If your setup uses our 2.0 Amp or 1.5 Amp BEC, and it is setup in a way that it is impossible to keep the battery wires reasonably short, a diode in series with the red BEC input wire will improve BEC performance (See *About Voltage Ripple* on page 10).

Always remember to insulate your connections with shrink tube.

Bad insulation or connections can cause short circuits, equipment damage, fire and personal injury.

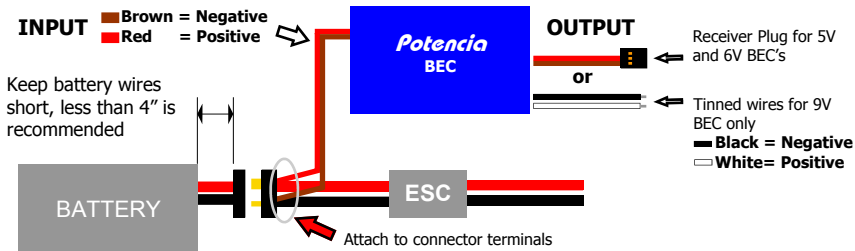

LOCATING THE BEC IN YOUR MODEL (ALL MODELS)

It is generally good practice to keep **all** your electronics away from the antenna and receiver. If you must mount the *Potencia* BEC near or next to the receiver, place the flat label side facing towards the receiver. Secure the BEC to the models frame or fuselage, **do not** stuff it in foam. The BEC can supply it's continuous current with no airflow at room temperature, however your model should have some airflow to prevent heat from building up inside the model.

CONNECTING THE BEC OUTPUT (ALL MODELS)

BEC models with an ESC Pass-Thru Connector

The 1.5A and the newer 2.0A and 3.5A BEC models feature an ESC pass-thru connector that makes wiring the *Potencia* BEC even easier. Connect the ESC plug to the three pin pass-thru connector on the BEC, aligning the colors as indicated on the label, and connect the BEC output plug to the same channel on the receiver where the ESC was plugged into (See diagrams on top of page 3). When using the pass-thru connection the red wire on the ESC plug does not have to be cut or removed. The *Potencia* BEC will supply power to the receiver and servos instead of the ESC, while the throttle signal passes straight though the *Potencia* BEC from the receiver to the ESC.

NOTE: The ESC Pass-Thru feature will not work for opto ESCs. When using an opto ESC do not connect the ESC to the pass-thru connector. Instead, connect the BEC and ESC as described for BEC models without an ESC pass-thru connector (see page 3) except do not remove the center red wire from the ESC plug.

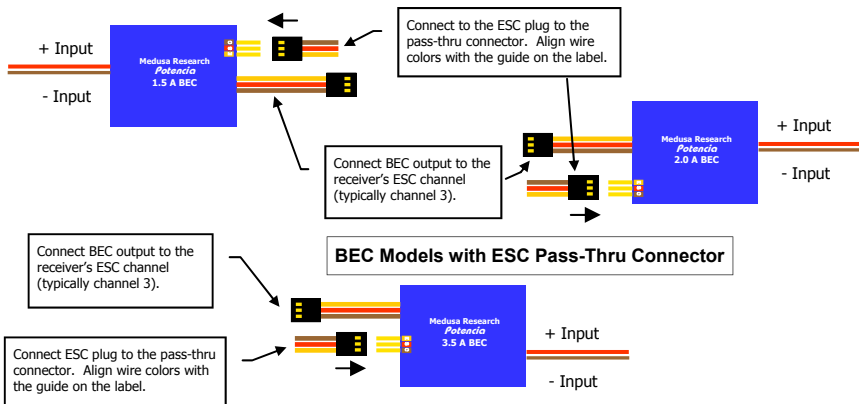

BEC models without an ESC Pass-Thru Connector

When using a BEC without an ESC pass-thru connector you must remove the center red wire on the ESC plug. The pin can be removed by gently lifting the plastic tab over the center pin and sliding it out. Tape up the pin so that it does not short to anything else. Connect the ESC plug (without the center red wire) to the throttle channel and plug the BEC output plug into the battery or any unused channel. If there are no unused channels available use a short "Y" connector plugged into the throttle channel and the BEC and ESC (see diagrams on next page).

NOTE: Always double check the polarity of all wires before applying power the first time.

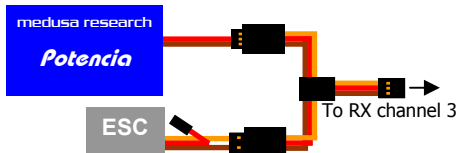

Remove and insulate the RED wire only if your ESC is equipped with a BEC

Using a Y-Harness to connect the Potencia

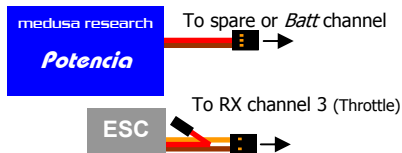

Remove and insulate the RED wire only if your ESC is equipped with a BEC

Using the "Batt" channel to connect the Potencia

Connecting a 9V BEC model

To connect a 9V BEC, the black and white wire should be spliced into a mating connector for your 9V accessory. Polarity for the output is black/ground and white/+9V as shown on the diagram, page 1.

VOTLAGE SELECTION

Only the 3.5A BEC has a selectable output voltage. The 1.5A and 2.0A models must be purchased with the desired output voltage.

The newer 3.5A BEC's now come with a switch. The prior model used a jumper.



- For 6V output, install the jumper
- For 5V output, remove the jumper

The jumper is recessed in the shrink wrap to protect it. You may need needle-nose pliers or tweezers to install or remove the jumper.

The switch is recessed in the shrink wrap to protect it. You may need a small screwdriver to change the switch position.

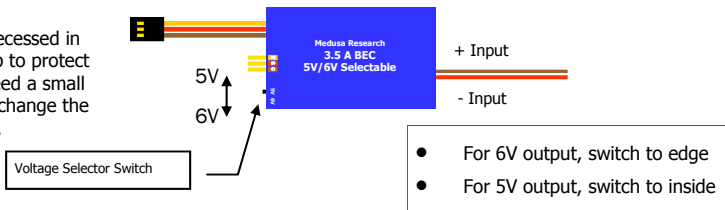

LED POWER INDICATOR

Newer *Potencia* BEC's have a red LED to indicate that output power is on.

CONNECTING BEC'S IN PARALLEL

You can connect two BEC's in parallel to obtain more amperage. The two BEC's must have the same voltage and amp rating. Do not shorten the output wires when doing so.

OPERATING THE BEC IN YOUR MODEL (ALL MODELS)

It is recommended that your ESC have low battery detection, or you must pay close attention to signs that your battery is low to prevent losing control of your model. Whenever you add parts or make changes to your model, perform a *range check*. Ensure the receiver, servos, and ESC will operate smoothly with the transmitter a good distance away from your model **before** you start flying.

IMPORTANT! The *Potencia* 3.5 Amp BEC was designed and optimized exclusively for high voltage systems that have at least 10 NiCd or NiMH cells, or at least 3 Lithium or LiPo cells. **Using the *Potencia* 3.5 Amp BEC with less than 8 volts can cause loss of power to the receiver. For lower voltage applications, use the *Potencia* 2 Amp or 1.5 Amp BEC instead. See 'Specifications' on pages 7 thru 9.**

SYMPTOM	SOLUTIONS
<p>After flying for a several minutes, I notice the motor's power output fading, Eventually the motor stops and the servos don't respond.</p>	<p>Your ESC is not equipped with low battery detection, or it is not enabled. The main battery has become so drained, it can not power the BEC. Unlike a system with a separate flight pack battery, your receiver and servos are relying on the main battery for power. This is true of all BEC circuits.</p> <ol style="list-style-type: none">1. See if your ESC is equipped with low battery detection, and enable it.2. Use a stopwatch to time your flights, and learn how long you can fly on a charge3. Replace your ESC with one that has low battery detection.
<p>I have connected everything for the first time and connected a battery to my model. I'm testing the servos by moving the transmitter controls, but the receiver and servos don't appear to have power.</p>	<ol style="list-style-type: none">1. Make sure your transmitter is on and has a freshly charged battery2. Make sure your model's battery is fully charged3. Double check the polarity of all your connections. If you have connected the BEC with reverse polarity, it is likely that the <i>Potencia</i> BEC is damaged. You should return the BEC to Medusa Research for testing and inspection before attempting to use it again.

Potencia 3.5 Amp BEC - SPECIFICATIONS

Parameter	Minimum	Maximum
NiCd/NiMH Cells	10	33
Li/LiPo Cells	3	10
Input Voltage	8 Volts ¹	45 Volts
Output Voltage (5 / 6 Volt model)	5 / 5.9 Volts	5.15 / 6.10 Volts
Continuous Output Current	No minimum load.	3.5 Amps
Peak output current	No minimum load	4 Amps for 6 minutes
Number of Standard Servos (typical)	No minimum number	8

Potencia 3.5 Amp BEC - WEIGHT AND DIMENSIONS

Parameter	Value
Width	30 mm (1.2 in)
Length	50 mm (2.0 in)
Thickness	13 mm (0.5 in)
Weight	20 g w/ wires ; 13.2g w/o wires

¹ Output voltage will be zero for input voltages less than the minimum.

Potencia 2 Amp BEC - SPECIFICATIONS

Parameter	Minimum	Maximum
NiCd/NiMH Cells	6	25
Li/LiPo Cells	2	8
Input Voltage	4.0 Volts ¹	35 Volts
Output Voltage (5V / 6V / 9V model)	5 / 6 / 9 Volts	5.15 / 6.20 / 9.25 Volts
Continuous Current (5V / 6V / 9V model)	No minimum load.	2 / 2 / 1.7 Amps
Peak output current	No minimum load	2.4 Amps for 4 minutes
Number of Standard Servos (typical)	No minimum number	4

Potencia 2 Amp BEC - WEIGHT AND DIMENSIONS

Parameter	Value
Width	24 mm (1.0 in)
Length	24 mm (1.0 in)
Thickness	9 mm (.34 in)
Weight	12 g w/ wires ; 6.2g w/o wires

¹ Output voltage will be zero for input voltages less than the minimum. For inputs less than rated output, output will track input.

Potencia 1.5 Amp BEC - SPECIFICATIONS

Parameter	Minimum	Maximum
NiCd/NiMH Cells	6	25
Li/LiPo Cells	2	8
Input Voltage	4.0 Volts ¹	35 Volts
Output Voltage (5V / 6V model)	5 / 6 Volts	5.15 / 6.20 Volts
Continuous Current (5V / 6V / 9V model)	No minimum load.	1.5 / 1.5 Amps
Peak output current	No minimum load	2.0 Amps for 4 minutes
Number of Standard Servos (typical)	No minimum number	3

Potencia 1.5 Amp BEC - WEIGHT AND DIMENSIONS

Parameter	Value
Width	21 mm (0.8 in)
Length	22 mm (0.9 in)
Thickness	9 mm (.34 in)
Weight	9 g w/ wires ; 5.5g w/o wires

¹ Output voltage will be zero for input voltages less than the minimum. For inputs less than rated output, output will track input.

ABOUT SERVO RATINGS

Servo counts are based on the peak BEC current, divided by the stall current of a standard servo. Our servo count calculations use 600mA peak current per servo, which is approximately the stall current many standard and micro servos. Our servo counts may be used as guidelines, however to be safe you should know the peak current of your specific servos, gyros, and other equipment running off the BEC.

ABOUT VOLTAGE RIPPLE

The 2 Amp Potencia can be adversely affected by excessive voltage ripple. Long battery wires and poor connections, in conjunction with high motor currents can aggravate voltage ripple problems. Read the *Connections* section for details about the best way to setup our BEC.

In a model with a less than optimal battery and ESC arrangement, BEC performance can be improved by installing a 2 Amp Schottky diode as shown. Cover the diode and exposed leads with heat shrink to prevent shorting.

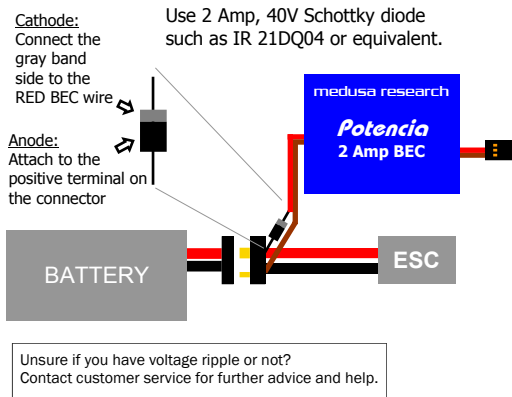

SUPPORT

If you are still having difficulties, or have questions that aren't covered in this manual, you can contact Medusa Research for support.

Our contact information is:

World Wide Web

<http://www.medusaproducts.com>

E-Mail

support@medusaproducts.com

Telephone Support

Hours: Monday-Friday 10am to 5pm eastern time, excluding business holidays

Phone Number: 508.675.0200 (in Fall River, Massachusetts)

RETURNS AND RETURN AUTHORIZATION:

For warranty and repair returns, please download a *returns form* from our website. Instructions for packaging and shipping returns are also on our website. If you do not have access to the internet, please call or fax us at the number below.

Medusa Research Inc.
288 Plymouth Avenue
Fall River, Massachusetts
02721-4226

Phone: 508.675.0200
Fax: 508.675.0202
Email: support@medusaproducts.com
Website: www.medusaproducts.com

LIMITED WARRANTY:

Medusa Research Incorporated warrants all *Potencia* BECs to be free of manufacturing defects in material and workmanship for a period of 12 months from the original date of purchase. Should any defects covered by this warranty be found, the *Potencia* BEC shall be repaired or replaced with a unit of equal performance by Medusa Research, Inc. In the event of a product defect during the warranty period, see the *Returns* section for return information.

LIMITS AND EXCLUSIONS:

This warranty may be enforced only by the original purchaser, who uses the High Voltage *Potencia* BEC in strict accordance with the information provided in this operation guide.

This Warranty does not apply to:

1. Damage resulting from failure to follow instructions provided in this operations guideline
2. Damage resulting from misuse, reverse polarity on input or output wires, abuse or neglect.
3. Damage occurring as a result of poor solder joints, connector incompatibility, or mechanical failure of user installed input and output connections.
4. Damage resulting from any repair or alteration performed by someone other than Medusa Research, Inc.

LIMITATION OF LIABILITY:

(i) UNDER NO CIRCUMSTANCES WILL MEDUSA RESEARCH, INC. BE LIABLE FOR ANY INDIRECT, THIRD PARTY, SPECIAL, INCIDENTAL, CONSEQUENTIAL OR EXEMPLARY EXPENSES, COSTS, LIABILITY, LOSS, OR DAMAGE WHATSOEVER IN ANY CONNECTION WITH THE USE OR MISUSE OF, OR INABILITY TO USE THIS PRODUCT;

(ii) that Medusa Research, Inc. shall not be liable for any harm, loss, damages, expenses, costs, suit, claim or demand whatsoever against the user of this product;

(iii) that neither Medusa Research, Inc., nor any of its representatives, employees, officers, directors, agents, distributors, affiliated corporations or any other person, shall be responsible for nor shall incur, any liability, damages, loss, obligations or responsibility whatsoever (whether in equity, contract, tort or otherwise) for any harm, loss, reliance, or damages, whatsoever, that may arise in any connection with or result from any promise, advice, arrangement, agreement, statement, technical support or maintenance, representation, warranty, or information whatsoever, that may have been made to by Medusa Research, Inc.;

Engineered Products for the RC Enthusiast

Copyright ©2007-2008
Medusa Research, Inc.
All Rights Reserved

No portion of this document may be reproduced or used in any form or by any means—graphic, electronic, or mechanical, including photocopying, recording, taping, or information storage and retrieval systems - without the written permission of Medusa Research, Inc.

Medusa Research, Inc.
288 Plymouth Ave.
Fall River, MA 02721
Phone: (508)675-0200
Fax: (508)675-0202
Email: info@medusaproducts.com

Document PN: 821A00011 Rev K
June 2008

www.MedusaProducts.com